

## Instructions for Use

# Care for Viega system press tools

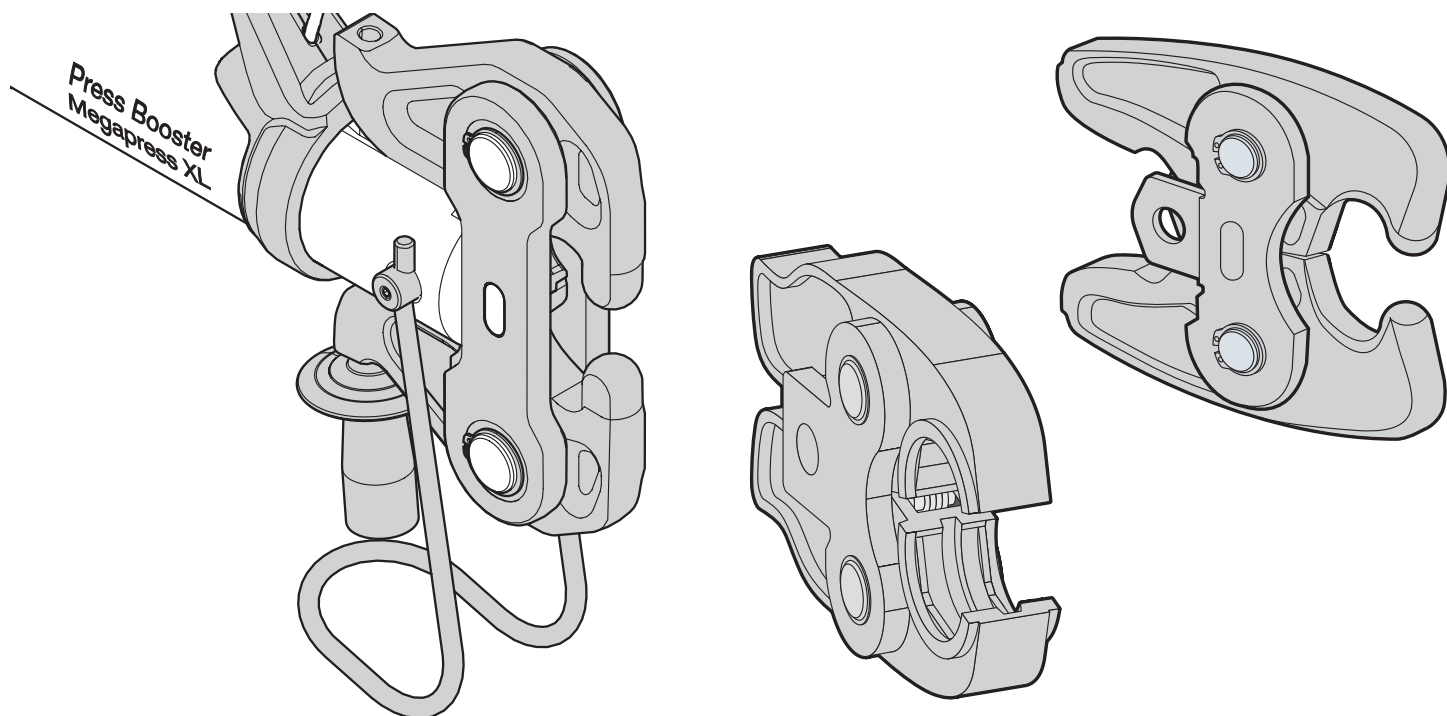

# Table of contents

<b>1</b>	<b>About these instructions for use</b>	<b>3</b>
	1.1 Target groups	3
	1.2 Labelling of notes	3
	1.3 About this translated version	4
<b>2</b>	<b>Product information</b>	<b>5</b>
	2.1 Intended use	5
	2.1.1 Areas of use	5
	2.2 Product description	5
	2.2.1 Overview	5
<b>3</b>	<b>Handling</b>	<b>8</b>
	3.1 Transport and storage	8
	3.2 Care and maintenance	8
	3.2.1 Performing checks	8
	3.2.2 Cleaning the press tools	8
	3.2.3 Inspection and maintenance	11
	3.3 Service partners	12
	3.4 Disposal	14

# 1 About these instructions for use

Trade mark rights exist for this document; for further information, go to [viega.com/legal](http://viega.com/legal).

## 1.1 Target groups

The information in this instruction manual is directed at the following groups of people:

- Heating and plumbing experts and trained personnel

Individuals without the abovementioned training or qualification are not permitted to mount, install and, if required, maintain this product. This restriction does not extend to possible operating instructions.

The use of Viega products must be carried out in accordance with the general rules of engineering and the Viega instructions for use.

## 1.2 Labelling of notes

Warning and advisory texts are set aside from the remainder of the text and are labelled with the relevant pictographs.



### **DANGER!**

This symbol warns of possible life-threatening injury.



### **WARNING!**

This symbol warns of possible serious injury.



### **CAUTION!**

This symbol warns of possible injury.



### **NOTICE!**

This symbol warns of possible damage to property.



This symbol gives additional information and hints.

### 1.3 About this translated version

This instruction for use contains important information about the choice of product or system, assembly and commissioning as well as intended use and, if required, maintenance measures. The information about the products, their properties and application technology are based on the current standards in Europe (e.g. EN) and/or in Germany (e.g. DIN/DVGW).

Some passages in the text may refer to technical codes in Europe/Germany. These should serve as recommendations in the absence of corresponding national regulations. The relevant national laws, standards, regulations, directives and other technical provisions take priority over the German/European directives specified in this manual: The information herein is not binding for other countries and regions; as said above, they should be understood as a recommendation.

## 2 Product information

### 2.1 Intended use

#### 2.1.1 Areas of use



Viega system press tools have been specifically designed for and adapted to the installation of the Viega press connector systems. If systems by other manufacturers are used, Viega cannot provide any warranties.



Please fulfil your duty of care and follow these care instructions. In this way, you achieve maximum functional safety between the maintenance intervals. The general principle "safety through maintenance" applies. If the advice is not followed, no responsibility for personal injury can be accepted.

### 2.2 Product description

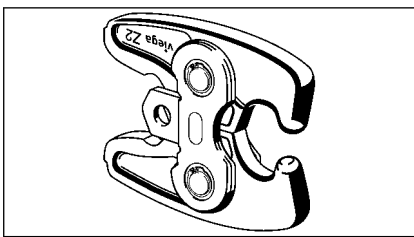
#### 2.2.1 Overview

	Model number
	2296.2, 2496.1
	2497.2XL, 2497.3XL 4296.1XL

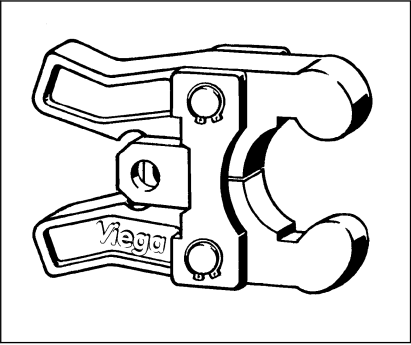
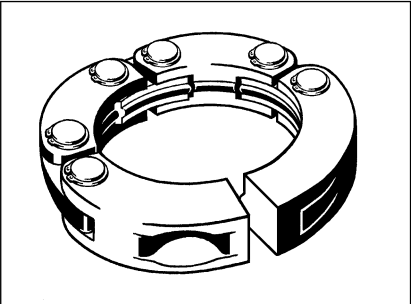
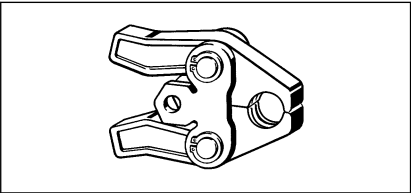
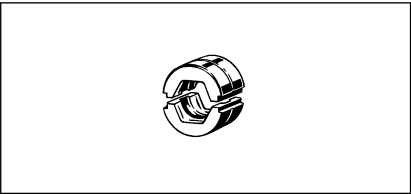
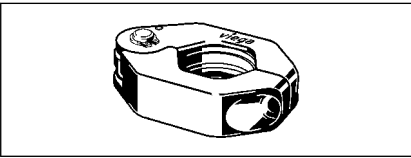
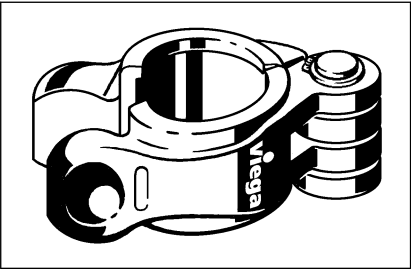
	Model number
	2297.1 XL
	2297.2XL, 2297.3XL
	2299.2, 2299.4, 2299.41, 2299.6, 2299.62, 2299.7, 2299.8, 2299.81, 2299.9, 2484.7, 2484.9, 2489.9, 2799.7, 4284.9, 4299.9 5384.7, 5399.7
	2499.2, 2499.1
	2296.1, 2296.4, 2496.3, 2496.5, 5396.1
	9696.1, 9696.6, 9696.7

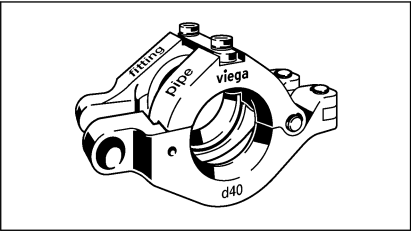
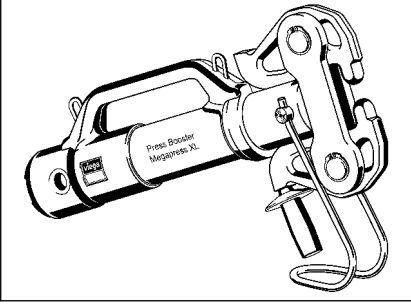
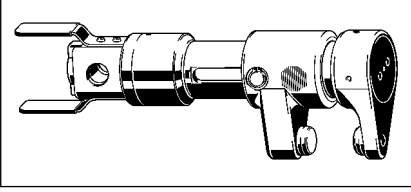
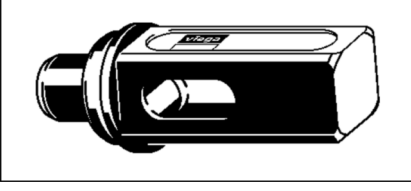
	Model number
 <p>A technical drawing of a pipe clamp. It is a circular, cast metal component with a central opening for a pipe. The clamp has several mounting points and a locking mechanism. Labels include 'VIEGA' on the top left, 'Pipe' in the center, 'Viega' on the top right, and 'd40' at the bottom center.</p>	9796.1, 9796.7
 <p>A technical drawing of a hand-operated press brander. It features a long handle with a trigger mechanism and a cylindrical body. The body is labeled 'Press Brander' and 'Merganser XL'. The Viega logo is visible on the handle.</p>	4296.4XL
 <p>A technical drawing of a hand-operated press brander, similar to the previous one but with a different handle design. It has a cylindrical body and a trigger handle. The Viega logo is visible on the handle.</p>	9796.7
 <p>A technical drawing of a hand-operated press brander with a rectangular body and a cylindrical end. It has a trigger handle and a locking mechanism. The Viega logo is visible on the top of the rectangular body.</p>	4278.90

## 3 Handling

### 3.1 Transport and storage

- Clean the press tools after use and lightly oil.
- Store the press tools in a clean and dry place.
- During transport, protect the press tools from mechanical influences.

### 3.2 Care and maintenance

#### 3.2.1 Performing checks

For trouble-free operation, perform checks in regular intervals:

- After every use, check the press contour of the press jaws, press chains and press rings as well as the ball heads of the hinged adapter jaws and the contact points of the press rings for damage or visible wear.
- Check the press jaws and press rings for smooth operation.
- Carry out a test pressing with the press connector inserted, and check the pressing point for formation of burrs.

In case of malfunctions, contact an authorised service partner.

#### 3.2.2 Cleaning the press tools



Application and care should be carried out by specialists in compliance with the servicing intervals.

- Regularly clean the press contours of the press jaws, press rings and press chains with fine steel wool or cleaning fleece in order to remove deposits and prevent corrosion (e.g. using the Viega cleaning fleece, art. no. 104 412).
- Apply maintenance oil to the hinges and all moving parts (art. no. 667 924). Move the tools and joints while lubricating them.

**INFO!** Note the pictures in chapter  'Greasing the lubrication points at the press tools' on page 9.

- Then thinly spray the press jaw or press ring with maintenance oil (art. no. 667 924) and let it work for a short time before wiping off with a lint-free cloth.



Every two years, have an authorised service partner (see [Chapter 3.3 'Service partners'](#) on page 12) carry out the maintenance.

### Greasing the lubrication points at the press tools

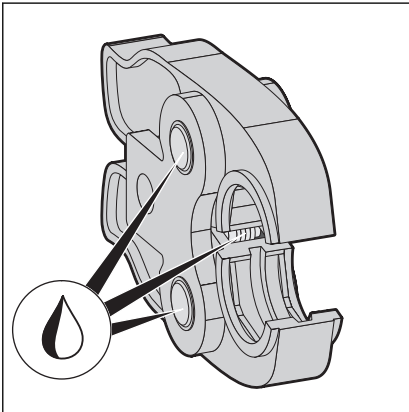

Lubrication points at a press jaw.

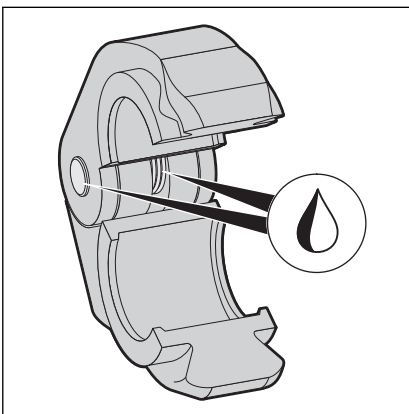

Lubrication points at a press ring.

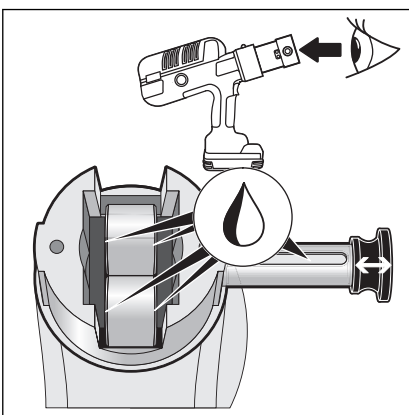

Lubrication points at press machines.

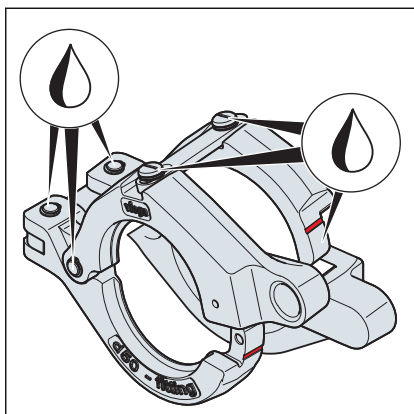

Lubrication points at the press ring Geopress K.

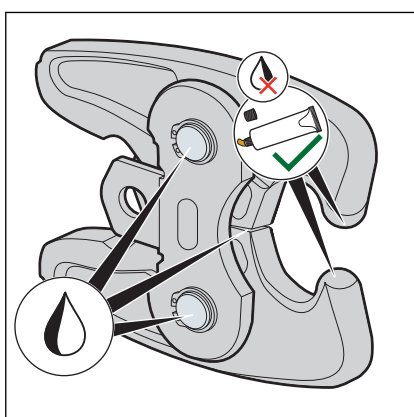

Lubrication points at a hinged adapter jaw Z2.

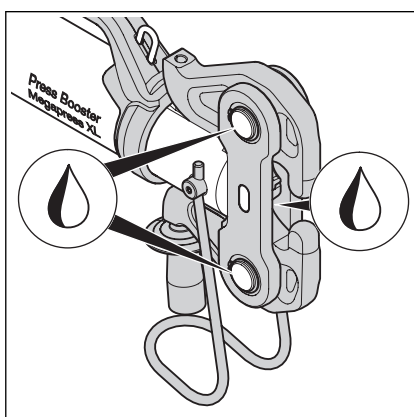

Lubrication points at Press Booster (hinged adapter jaw Z3).

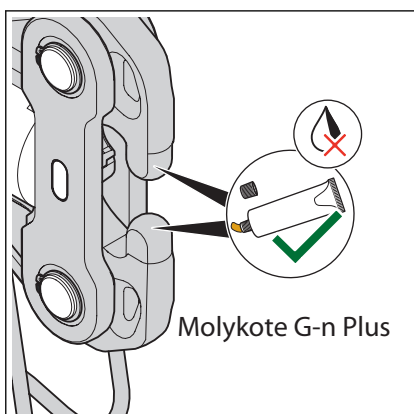

Lubrication points on the ball heads.

Use paste Molykote G-n Plus (art. no. 794 910).

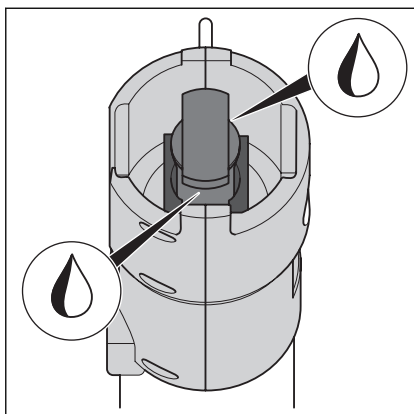

Lubrication points at the press ring drive.

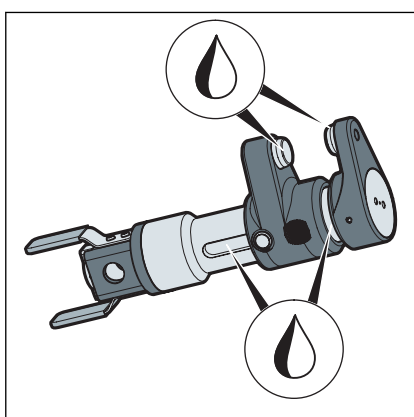

Lubrication points at the press-in tool.

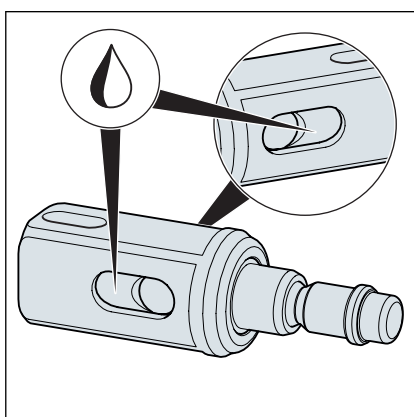

### 3.2.3 Inspection and maintenance

Viega recommends to have the system press jaws, chains, and rings regularly by a service partner. During the procedure, wear parts are replaced, press jaw contours are revised and the system press jaws, chains and rings are reset.

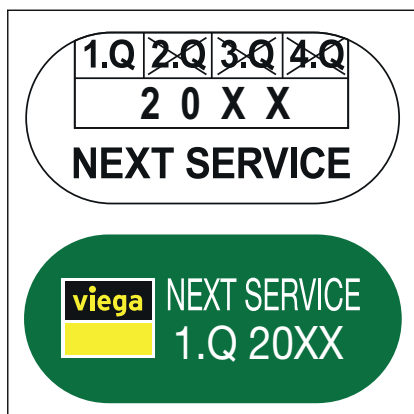

Fig. 1: Variants of the maintenance label (example representation)

oben: Variant 1

unten: Variant 2, from 2019, with annually changing colour shade

The Viega system press jaws and system press rings have a label showing the date when the next maintenance is due. Respect the maintenance dates in order to guarantee safety and proper function. After completed maintenance, the Viega service partner will apply a new sticker.

### 3.3 Service partners

For maintenance and repair of the press tools, contact the service partner in your country.

Country code	Company	Address/contact
A	König & Landl GmbH	Gewerbering 2, 2020 Hollabrunn <a href="https://www.koenig-landl.at">https://www.koenig-landl.at</a> / <a href="mailto:reparaturen@koenig-landl.at">reparaturen@koenig-landl.at</a> +43 (01) 479 74 84-50 / +43 (01) 479 74 84-55
OFF	Nepean Boltmaster Pty Ltd ABN	42 Borec Road, 2750 Penrith +61 (2) 4722 3034 / <a href="mailto:warren@nepbolt.com.au">warren@nepbolt.com.au</a>
	Allied Power Tools Pty. Ltd.	12/76 Rushdale St, Knoxfield, VIC 3180 +61 (3) 9764 2911/ <a href="mailto:alliedservice@aanet.com.au">alliedservice@aanet.com.au</a>
B	OMICRON-Benelux bvba	Grote Steenweg 116, 3454 Rummen-Geetbets +32 (11) 58 43 50 / <a href="mailto:rudy.massa@omicron-weldingtechnology.com">rudy.massa@omicron-weldingtechnology.com</a>
CN	德房家（中国）管道系统有限公司	无锡市锡山区万全路 30 号平谦国际现代产业园 P 栋 400 0688 668/ <a href="mailto:Dong.ji@viega.cn">Dong.ji@viega.cn</a>
	Viega (China) Plumbing Systems Co., Ltd.	Building P, Pingqian International Modern Industrial Park, No. 30 Wanquan Road, Xishan District, Wuxi, China (214107) 400 0688 668/ <a href="mailto:Dong.ji@viega.cn">Dong.ji@viega.cn</a>
CZ / SK	Mátl & Bula, spol. s r.o.	Stará pošta 750, 664 61 Rajhrad u Brna +420 547 424 424 / <a href="mailto:info@matl-bula.cz">info@matl-bula.cz</a>
D	Hans-Joachim Voigt & Sohn	Nordlichtstrasse 48/50, 13405 Berlin +49 (30) 413 4041 / <a href="mailto:m.sturtz@voigt-und-sohn.de">m.sturtz@voigt-und-sohn.de</a>
	Hamburger-Hochdruck-Hydraulik GmbH	Billwerder Billdeich 601c, 21033 Hamburg +49 (40) 7511 900 / <a href="mailto:Service@HHHydraulik.com">Service@HHHydraulik.com</a>

Country code	Company	Address/contact
	Hamburger-Hochdruck-Hydraulik GmbH – Süd	Neue Gautinger Str. 21, 82110 Germering, +49 (89) 130 111 03 / Service@HHHydraulik.com
DK	Scherer's Elektro ApS	Resenbrovej 4, 2610 Rodovre +45 (44) 843738 / Steffen@scherers-elektro.dk
E	Tecno Izquierdo S.L.	Avda. del Manzanares 222, 28026 Madrid +34 (914) 759158 / tecno.izquierdo@telefonica.net
F	PLASTIPRO	245 boulevard de l'Europe, 62118 Monchy-le-Preux +33 (361) 47 40 45 / contact@sarl-plastipro.fr
FN	Sähköhuolto Tissari Oy	Pojjutie 3, 70460 Kuopio + 358 (17) 26 48 500 / osmo.tissari@sht.fi
GR	Ergon Equipment A.E.T.E.	102 Kleisthenous & Papafiessa Str, 153 44 Athens +30 (210) 604945 4 / astathis@ergon.com.gr
I	Elmes KG	Via Artigianale Nord, 6, 39044 Neumarkt +39 (0471) 813399 / info@elmes.it
I	O.R.E. s.r.l.	Via Sassonia, 16/G, 47900 Rimini +39 (0541) 741003 / info@oreutensili.com
JP	Toyo Kiko Inc.	717-5 Shimokuya-machi, 378-0061 Numata-shi +81 (278) 24 41 77 / r.adachi@toyo-fit.co.jp
NO	Grønvold Maskinservice A/S	Brobekkveien 104 A, 0613 Oslo +47 (23) 05 06 40 / Terje@gronvoldmaskin.no
NL	MG Service	Canadabaan 2, 5388 RT Nistelrode +31 (412) 617 299 / info@mgservice.nl
RU	KONTURS-SDM	Московская область, Солнечногорский район, Ленинградское шоссе, 34 км., стр. 15 (полигон МАДИ) +7 (499) 702-45-88 / remont@konturs-sdm.ru
S	Elektroverkstaden Kent Andersson AB	Propellervägen 7, 39241 Kalmar +46 (732) 30 57 40/ info@elektrov.se
UK	MEP LLA Glasgow - Depot 190	Unit K, Ashley Drive Bothwell, G71 8BS Glasgow +44 (1698) 740047 / angela.hepburn@vpplc.com
	Broughton Plant Hire	Unit 10, Trade City, Ashton Road, RM3 8UJ Romford, Essex +44 (1708) 383350 / steve@mbroughtonltd.co.uk

## 3.4 Disposal

Separate the product and packaging materials (e. g. paper, metal, plastic or non-ferrous metals) and dispose of in accordance with valid national legal requirements.



**Viega Supply Chain GmbH & Co. KG**

service-technik@viega.de

viega.com

INT • 2020-10 • VPN190583

